

**OTAM<sup>®</sup>**



Equipamentos de Ventilação

Ventiladores Centrífugos  
Tipo Sirocco

**TMD**

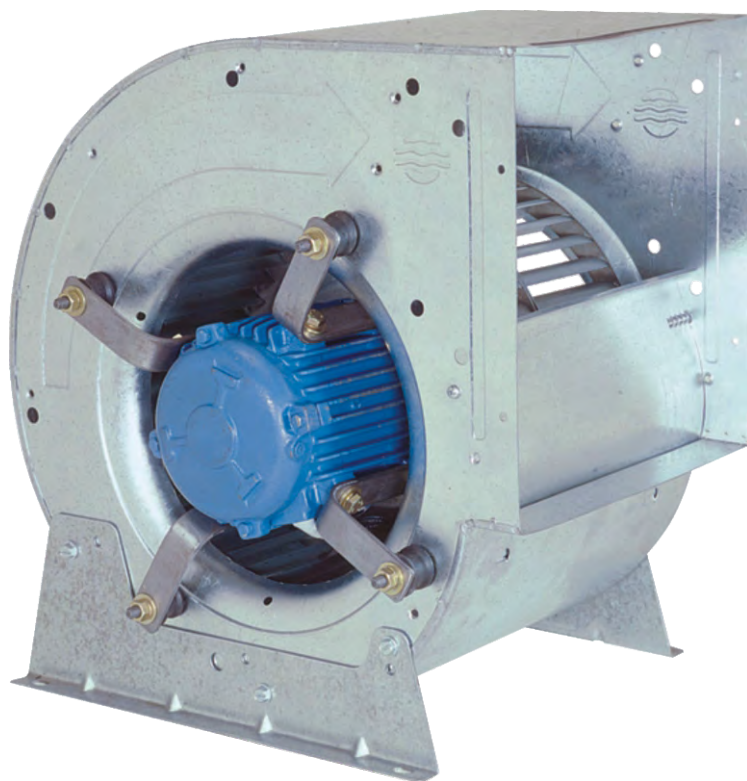

**Soler&Palau**





## TABELA DIMENSIONAL E CURVAS CARACTERÍSTICAS

### TMD-L

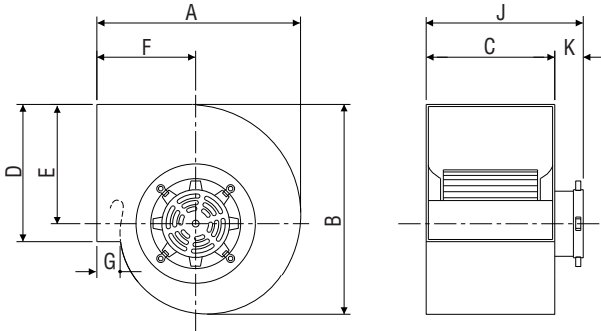

TAM.	A	B	C	D	E	F	G	J	K	Peso (Kg)
<b>9/7</b>	376,5	391	249	265	218	180	34	305	56	14,9
<b>9/9</b>	376,5	391	298	265	218	180	34	329	31	16,9
<b>10/8</b>	427	441	274	289	246	207	38	320	46	17,3

### TMD-SR

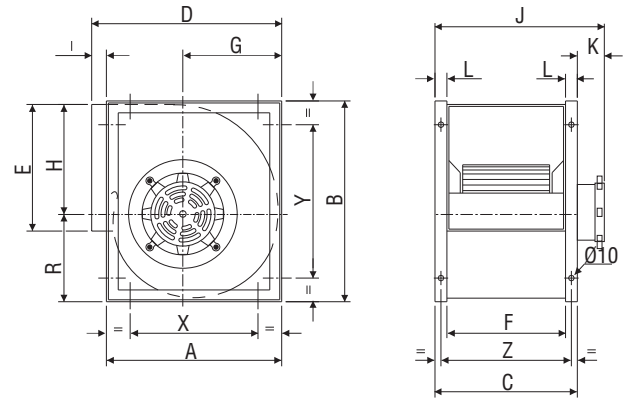

TAM.	A	B	C	D	E	F	G	H	I	J	K	L	R	X	Y	Z	Peso (Kg)
<b>9/7</b>	351	400	297	378	265	249	198	218	27	329	32	24	178	280	327	274	16,9
<b>9/9</b>	351	400	346	378	265	298	198	218	27	353	7	24	178	280	327	323	19,4
<b>10/8</b>	402	452	322	432	289	274	225	246	30	344	22	24	201	326	377	299	19,8

### Curvas características

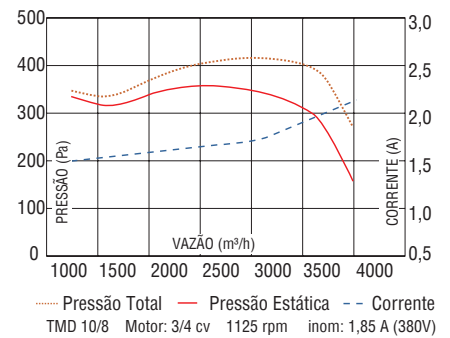
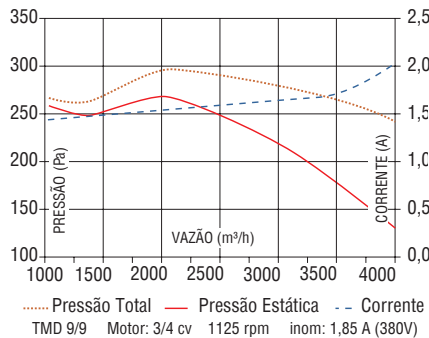
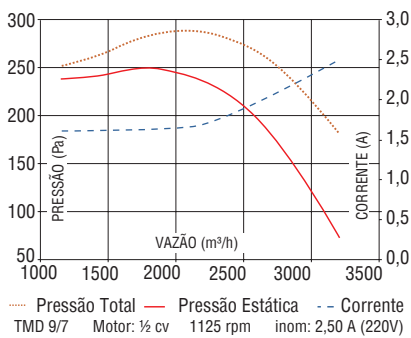

Condições do ar: Temperatura 20°C; Pressão Barométrica 760 mmHg

### Dimensões segundo a posição

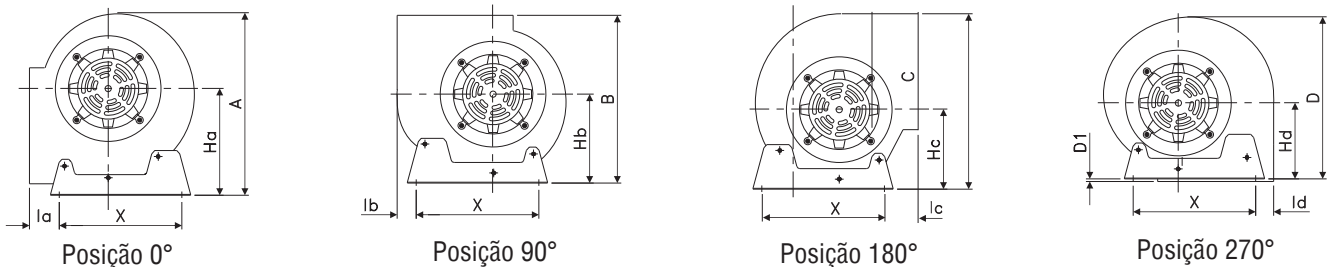

TAMANHO	X	POSIÇÃO 0°			POSIÇÃO 90°			POSIÇÃO 180°			POSIÇÃO 270°			
		A	Ha	la	B	Hb	lb	C	Hc	lc	D	D1	Hd	ld
<b>9/7 e 9/9</b>	280	417	244	68	383	203	43,5	401	183	77	370,5	6	174	41
<b>10/8</b>	317	471	276	73,5	435,5	228,5	49	450,5	204,5	85	421,5	5,5	201,5	71



## **S&P BRASIL VENTILAÇÃO LTDA**

Av. Francisco Silveira Bitencourt, 1501  
Porto Alegre/RS - Tel. 55 51 3349 6363

Filial: São Paulo/SP - Tel. 55 11 3539 5313

[www.solerpalau.com.br](http://www.solerpalau.com.br)  
[comercialBR@solerpalau.com](mailto:comercialBR@solerpalau.com)  
[comercialBRSP@solerpalau.com](mailto:comercialBRSP@solerpalau.com)

